

Smart Vision Sensors

ZFV Color Series



ZFV

Ordering Information

Models

Sensor Heads

Appearance	Type	Setting distance	Sensing area	Model
	Narrow View	34 to 49 mm (variable)	5 × 4.6 mm to 9 × 8.3 mm (variable)	ZFV-SC10
	Standard View	31 to 187 mm (variable)	10 × 9.2 mm to 50 × 46 mm (variable)	ZFV-SC50
	Wide View	66 to 141 mm (variable)	50 × 46 mm to 90 × 83 mm (variable)	ZFV-SC90
	Ultra-wide View	114 to 226 mm (variable)	90 × 83 mm to 150 × 138 mm (variable)	ZFV-SC150

Amplifier Units ZFV Color Series

Appearance	Power supply	Output type	Model
	24 VDC	NPN	ZFV-CA40
		PNP	ZFV-CA45

Accessories ZFV Color Series (order separately)

Data Storage Units

Appearance	Power supply	Output type	Model
	24 VDC	NPN	ZS-DSU11
		PNP	ZS-DSU41

Controller Link Unit

Appearance	Model
	ZS-XCN

External Lighting

Type	Model
Bar Lighting	ZFV-LTL01
Bar Double Lighting	ZFV-LTL02
Bar Low-angle Lighting	ZFV-LTL04
Light Source for Through-beam Lighting	ZFV-LTF01

Sensor Head Extension Cable

Cable length	Model
3 m	ZFV-XC3B *1
8 m	ZFV-XC8B

*1: ZFV-XC3BR Robot Cable is also available.

Panel-mounting Adapter

Appearance		
Model	ZS-XOM1	ZS-XPM2
	First Unit	Additional Units (for expansion)

Specifications

Sensor Heads

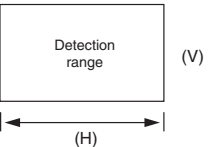
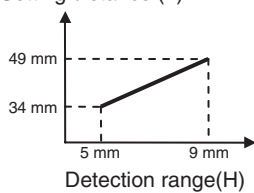
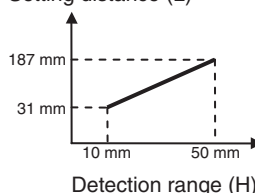
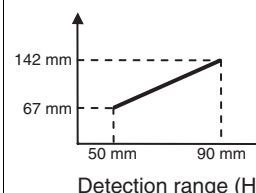
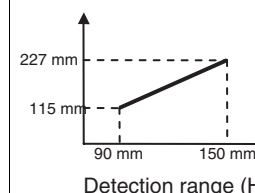
Item	ZFV-SC10 (Narrow View)	ZFV-SC50/SC50W (Standard View)	ZFV-SC90/SC90W (Wide View)	ZFV-SC150/SC150W (Ultra Wide View)
Setting distance (L)	34 to 49 mm (variable)	31 to 187 mm (variable)	67 to 142 mm (variable)	115 to 227 mm (variable)
Detection range (H × V) 	5 × 4.6 mm to 9 × 8.3 mm (variable)	10 × 9.2 mm to 50 × 46 mm (variable)	50 × 46 mm to 90 × 83 mm (variable)	90 × 83 mm to 150 × 138 mm (variable)
Relation between setting distance and detection range	Setting distance (L) 	Setting distance (L) 		
Built-in lens	Focus: f15.65	Focus: f13.47	Focus: f6.1	
Object lighting method	Pulse lighting			
Object light source	8 white LEDs	36 LEDs	20 white LEDs	72 white LEDs
Lightning I/F (Option)	None	Yes		None
Sensing element	1/3-inch CCD			
Shutter	Electronic shutter, shutter time: 1/500 to 1/8,000			
Power supply voltage	15 VDC (Supplied from Amplifier Unit.)	15 VDC, 48 VDC (Supplied from Amplifier Unit.)		
Current consumption	Approx. 200 mA	Approx. 350 mA [15 V: approx. 150 mA, 48 V: approx. 200 mA] (Including the current consumed when external light is connected)		
Dielectric strength	1,000 VAC, 50/60 Hz for 1 min			
Vibration resistance (destructive)	10 to 150 Hz, 0.35 mm single amplitude, 10 times each in X, Y, and Z directions for 8 min			
Shock resistance (destructive)	150 m/s ² , three times each in six directions (up/down, left/right, forward/backward)			
Ambient temperature	Operating: 0 to +40 °C, Storage: -25 to +65 °C (with no icing or condensation)			
Ambient humidity	Operating and storage: 35% to 85% (with no condensation)			
Ambient atmosphere	Must be free of corrosive gas.			
Connection type	Prewired, Standard cable length: 2 m			
Degree of protection (IEC 60529)	IP65	ZFV-SC___: IP65 ZFV-SC___W: IP67		
Material	Case: ABS, Mounting bracket: PBT			
Weight	Approx. 200 g (including mounting bracket and cord; packaged condition: approx. 300 g)	Approx. 270 g (including mounting bracket and cord; packaged condition: approx. 350 g)	Approx. 300 g (including mounting bracket and cord; packaged condition: approx. 380 g)	Approx. 600 g (including mounting bracket and cord; packaged condition: approx. 780 g)
Accessories	Mounting bracket ZFV-XMF (1), Ferrite core (1), Instruction sheet	Mounting bracket ZFV-XMF2 (1), Ferrite core (2), Warning label (1) Instruction sheet	Mounting bracket ZFV-XMF2 (1), Ferrite core (2), Warning label (1) Instruction sheet	Ferrite core (2), Instruction sheet
LED class ^{*1}	Class 1	Class 2	Class 2	Class 1

*1. Applicable standards: IEC60825-1: 1993 +A1:1997 +A2:2001, EN60825-1:1994 +A:2002 +A:2001

Amplifier Units

Item		ZFV-CA40	ZFV-CA45
Output specifications		NPN open collector, 30 VDC 50 mA max., residual voltage 1.2 V max.	PNP open collector, 50 mA max., residual voltage 1.2 V max.
Input specifications	ON	Short-circuited with 0 V terminal or 1.5 V or less	Supply voltage short-circuited or within supply voltage -1.5 V max.
	OFF		
Serial I/O	USB2.0	1 port, full-speed (12 Mbps) MINI-B	
	RS-232C	1 port, 115,200 bps max.	
Inspection items		PATTERN, AREA, HUE (Color), WIDTH, POSITION, COUNT, BRIGHT, CHARA	
Teaching area		Rectangular, one area	
Teaching area size		<ul style="list-style-type: none"> • PATTERN, BRIGHT: Any rectangular area (256 × 256 max.) • AREA, HUE (Color), WIDTH, POSITION, COUNT, CHARA: Any rectangular area (full screen max.) 	
Sensing area		Full screen	
Resolution		468 x 432 (H x V) max.	
Bank switching		Supported for 8 banks.	
Image input interval		13 ms (Standard), 8 ms (1/2 for partial scan), 5 ms (1/4 for partial scan)	
Other functions		Control output switching: ON for OK / ON for NG, ON delay / OFF delay, One-shot output, "ECO" mode	
Output signals		(1) Control output (OUTPUT) (2) Enable output (ENABLE) (3) Error output (ERROR)	
Input signals		(1) Sync measurement input (TRIG)/Continuous measurement input (TRIG); switched by menu (2) Bank selection inputs (BANK1-3) (3) Workpiece still teaching (TEACH)/ Workpiece moving teaching (TEACH); switched by menu	
Sensor head interface		Digital interface	
Image display		1.8 inch TFT ccolor LCD (Display dots: 557 x 234 pix)	
Indicators		<ul style="list-style-type: none"> • Judgment result indicator (OUTPUT, Color: orange) • Inspection mode indicator (RUN, Color: green) • Error indicator (ERR, Color: red) • Ready status indicator (READY, Color: blue) 	
Operation interface		<ul style="list-style-type: none"> • Cursor keys (up, down, left, right) • Setting key (SET) • Escape key (ESC) • Operating mode switching (slide switch) • Menu switching (slide switch) • Teaching/Display switching key (TEACH/VIEW) • Function keys (A to D 4 input) 	
Power supply voltage		20.4 to 26.4 VDC (including ripple)	
Current consumption		800 mA max. (with Sensor Head connected)	
Dielectric strength		1,000 VAC, 50/60 Hz for 1 min between leads and Amplifier Unit case	
Noise resistance		1 kV, Pulse rise: 5 ns, Pulse width: 50 ns, Burst duration: 15 ms, Cycle: 300 ms	
Vibration resistance (destructive)		10 to 150 Hz, 0.1 mm single amplitude, 10 times each in X, Y, and Z directions for 8 min	
Shock resistance (destructive)		150 m/s ² , three times each in six directions (up/down, left/right, forward/backward)	
Ambient temperature range		Operating: 0 to 50 °C Storage: -25 to 65 °C (with no icing or condensation)	
Ambient humidity range		Operating and storage: 35% to 85% (with no condensation)	
Ambient atmosphere		Must be free of corrosive gas.	
Degree of protection		IEC 60529, IP20	
Material		Polycarbonate (PC)	
Weight		Approx. 300 g (including cord; packaged condition: 450 g)	
Accessories		Ferrite core (1), Instruction sheet, Label (1)	

External light units (optional)

Item	ZFV-LTF01	ZFV-LT01	ZFV-LTL01	ZFV-LTL04
Applicable sensor head	ZFV-SC50/SC50W/SC90/SC90W			
Lighting method	Pulse lighting			
Lighting interval	Fixed (1.1 to 1.4 ms)			
Light source (Qty.)	White LEDs			
	60	20	40	80
Power supply voltage	48 VDC (Supplied from sensor head)			
Current consumption	Approx. 160 mA	Approx. 80 mA	Approx. 120 mA	Approx. 210 mA
Dielectric strength	300 VAC, 50/60 Hz for 1 min			
Vibration resistance (destructive)	10 to 150 Hz, 0.35 mm single amplitude, 10 times each in X, Y and Z directions for 8 min			
Shock resistance (destructive)	150 m/s ² , 3 times each in six directions (up/down, left/right, forward/backward)			
Ambient temperature	Operating: 0 to 40 °C Storage: -20 to 65 °C (with no icing or condensation)			
Ambient humidity	Operating and storage: 35% to 85% RH (with no condensation)			
Ambient atmosphere	Must be free of corrosive gas			
Connection type	Prewired, Standard cable length: 2 m			
Degree of protection	IEC6D529 IP20			
Material	SPCC	SPCC, aluminium		
Weight	Approx. 500 g (when packaged: Approx. 550 g)	Approx. 250 g (when packaged: Approx. 300 g)	Approx. 650 g (when packaged: Approx. 900 g)	Approx. 900 g (when packaged: Approx. 1,150 g)
LED class	Class 1 Applicable standards IEC6D825-1: 1993 +A1:1997 +A2:2001 EN60825-1: 1994 +A1:2002 +A2:2001			

Dimensions (Units: mm)

Sensor Heads

ZFV-SC10 (Narrow view)

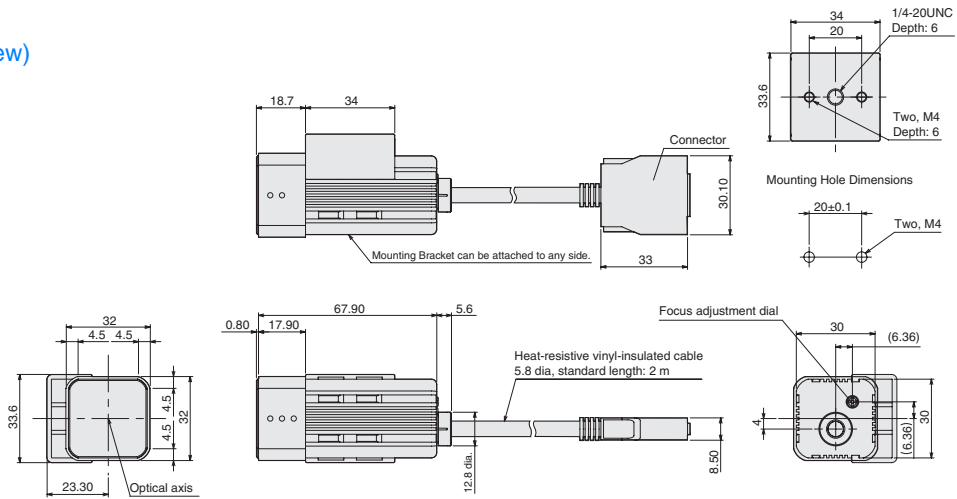

ZFV-SC50/SC50W (Standard view)

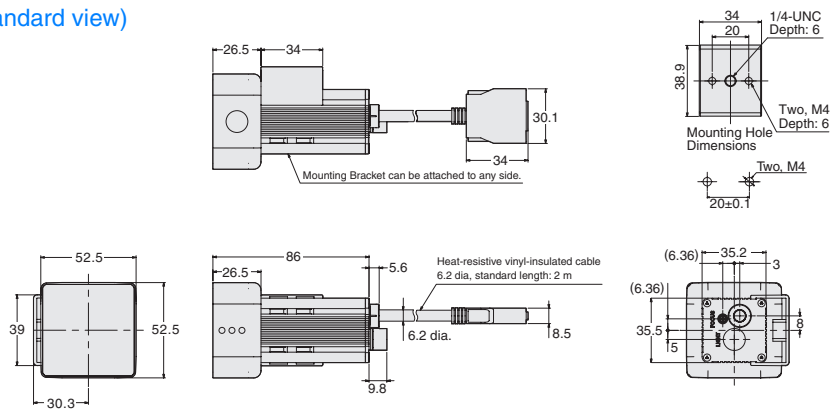

ZFV-SC90/SC90W (Wide view)

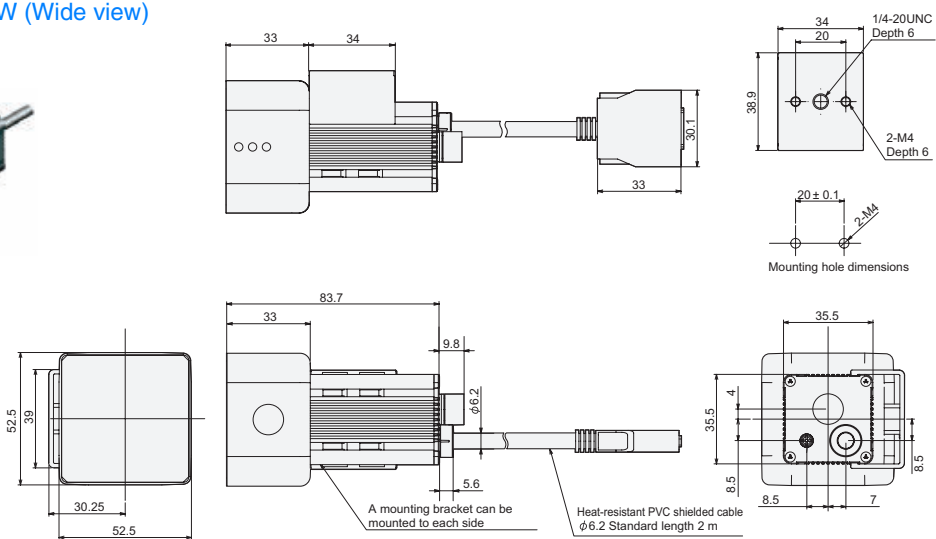

ZFV

ZFV-SC150/SC150W (Ultra wide view)

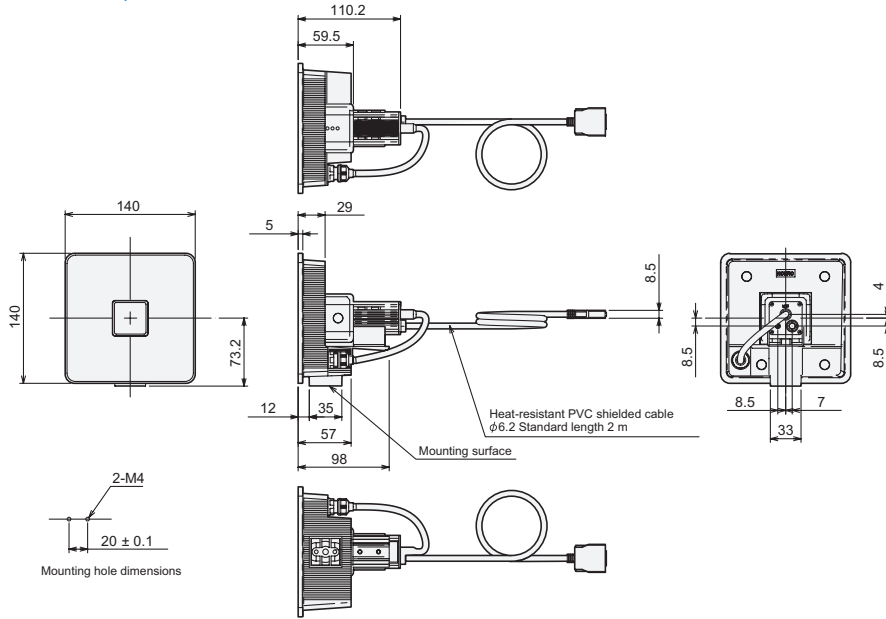

Amplifier Units

ZFV-CA4□

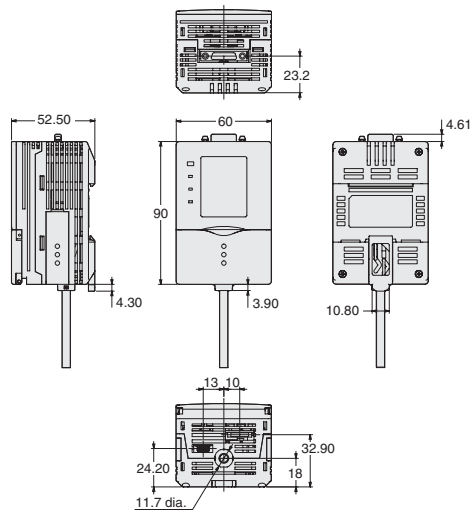

External light units (optional)

ZFV-LTL01 (bar lighting)

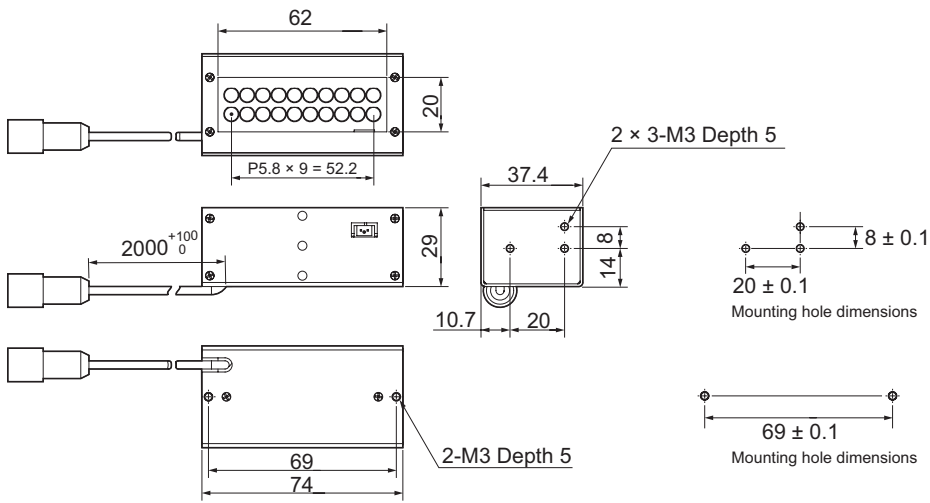

ZFV-LTL02 (bar double-lighting)

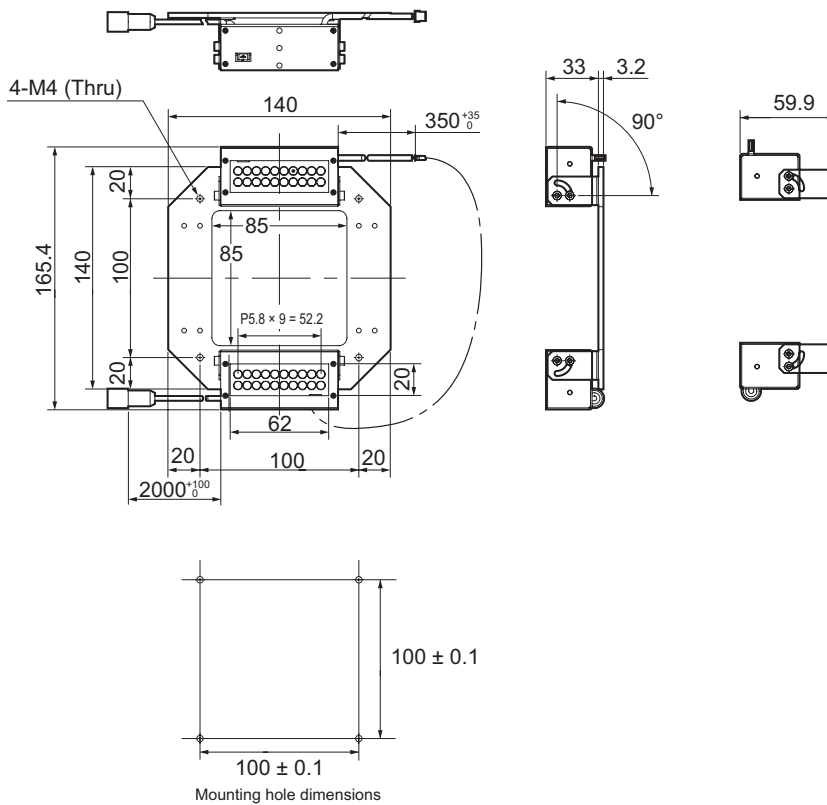

ZFV

About the I/O cable

The following shows the leads that comprise the I/O cable.

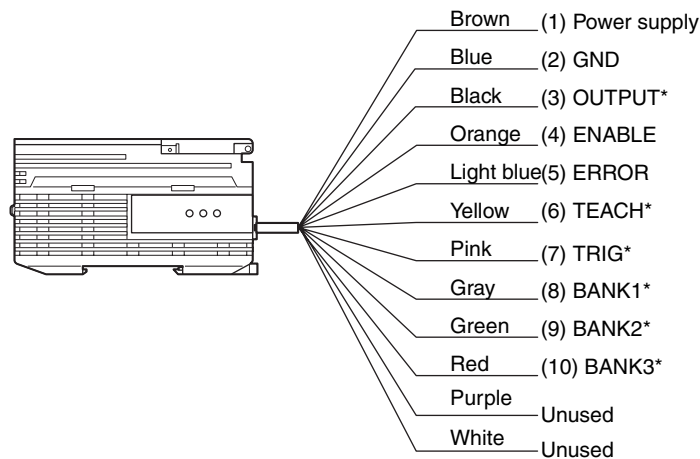

* : Enabled only in the RUN mode

- (1) **Power Supply**
This connects the power supply.
Use a DC power supply with safe extra-low-voltage circuits to prevent high voltage.
Wire the power supply separately from other devices. Wiring them together or placing them in the same duct may cause induction, resulting in malfunction or damage.
- (2) **GND**
The GND terminal is the 0 V power supply terminal.
- (3) **OUTPUT (control output)**
This outputs judgment results. This lead is interlocked with OUTPUT LED.
- (4) **ENABLE (enable output)**
This turns ON when error is generated. This leads is interlocked with ERR LED.
- (5) **ERROR (error output)**
This turns ON when an error is generated. This lead is interlocked with ERR LED.
- (6) **TEACH (teching output)**
There are two teaching modes, workpiece stop teaching and workpiece move teaching. These teaching modes can be selected in the menu.
- (7) **TRIG (measurement trigger input)**
There are two measurement modes, synchronus measurement and continuos measurement. Which mode of measurement is to be performed in is selected in the menu.
- (8) **BANK1 (bank swichting input 1)**
- (9) **BANK2 (bank swichting input 2)**
- (10) **BANK3 (bank swichting input 3)**

The bank No. can be switched when the BANK1 to BANK3 are connected as follows

Bank No.	BANK1	BANK2	BANK3
BANK1	OFF	OFF	OFF
BANK2	ON	OFF	OFF
BANK3	OFF	ON	OFF
BANK4	ON	ON	OFF
BANK5	OFF	OFF	ON
BANK6	ON	OFF	ON
BANK7	OFF	ON	ON
BANK8	ON	ON	ON

I/O Circuit diagrams

NPN output type (ZFV-CA40)

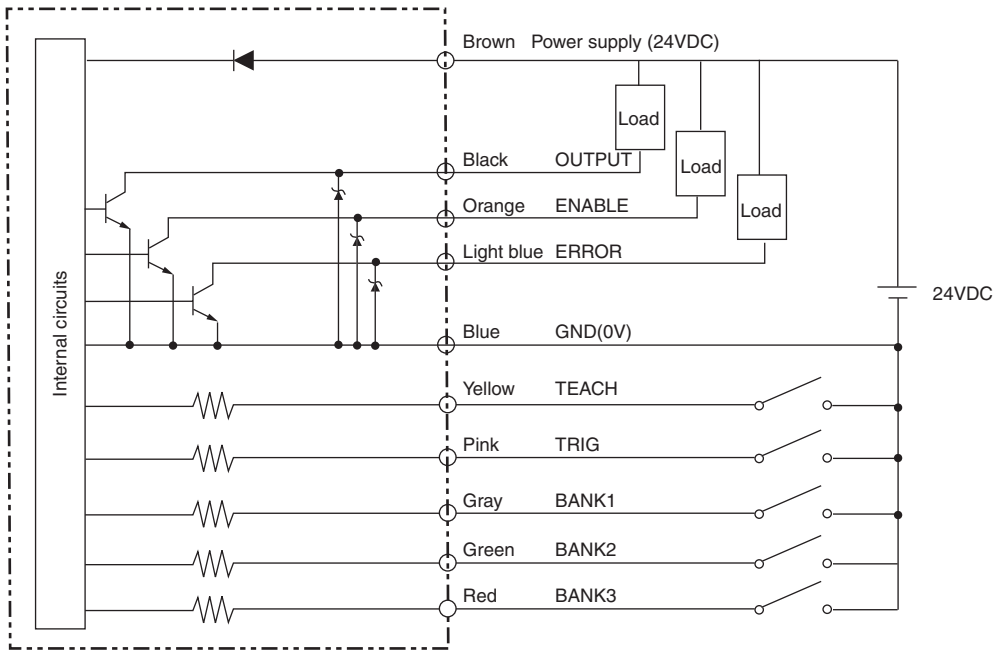

PNP output type (ZFV-CA45)

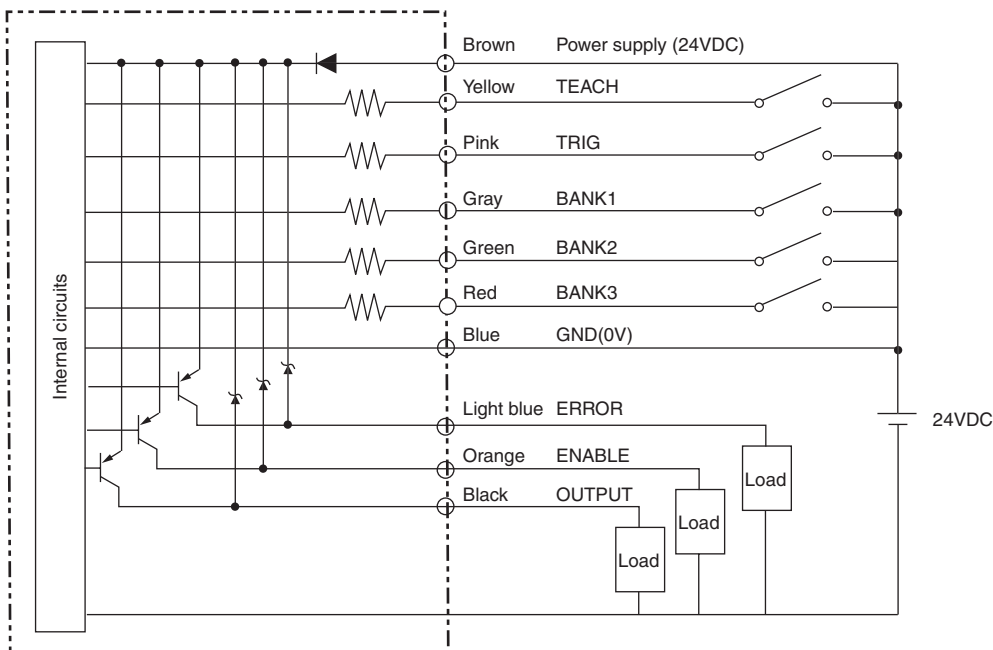

Timing Charts

The following shows the timing charts when communication is performed with external devices.

Measurement

Continuos measurement

Measurement is performed continuously for the duration that the TRIG signal is ON.
The measurement result is updated and output to external devices at each measurement cycle.

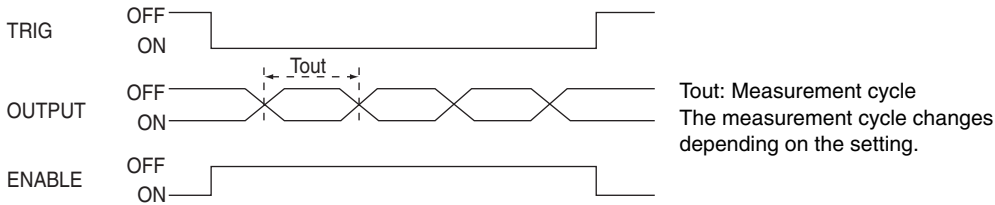

Synchronuos measurement

Measurement is performed only once in synchronus with the change in TRIG signal state from OFF to ON and the result is output.

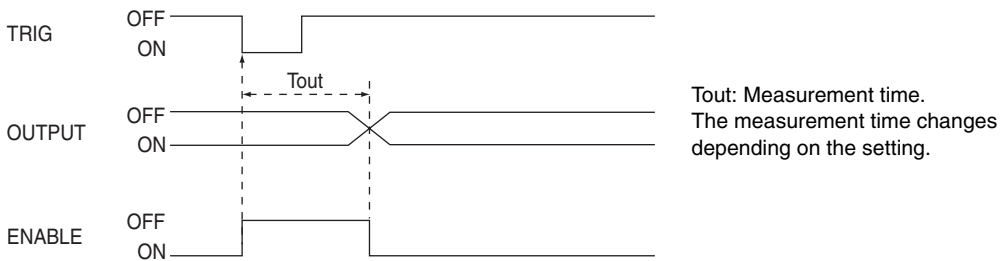

- The minimum ON time width of the TRIG signal is 1 ms.
 - The OUTPUT signal is held until the measurement result is updated.
- Note:** However, when one-shot is set, the OUTPUT signal is held for the preset time.

Teaching

Workpiece stop teaching

Teaching processing is performed according to TRIG signal input after the TEACH signal input.

Measurement is not performed while teaching is being performed. Do not move the workpiece until teaching is completed.

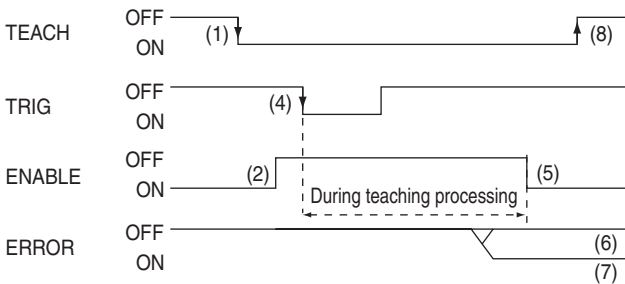

- (1) Turn the TEACH signal ON.
- (2) Confirm that the ENABLE signal has turned OFF.
- (3) Make sure that the workpiece to be taught is in the teaching area.
- (4) Input the TRIG signal.
- (5) The ENABLE signal turns ON after teaching is completed. At this timing, check the state of the ERROR signal.
- (6) When teaching has been completed successfully, the ERROR signal stays OFF.
- (7) When teaching fails, the ERROR signal turns ON.
- (8) Turn the TEACH signal OFF and end teaching processing.
When teaching fails, the state before teaching was initiated is returned to. Performe teaching again.
If the TEACH signal is turned OFF midway, teaching is disabled.

Workpiece move teaching

Use this teaching mode when the object cannot be stopped. Teaching processing is divided up and performed in synchronous with the TRIG signal input after the TEACH signal is input.

Teaching must be processewd eight times. Measurement is not performed while teaching is being performed.

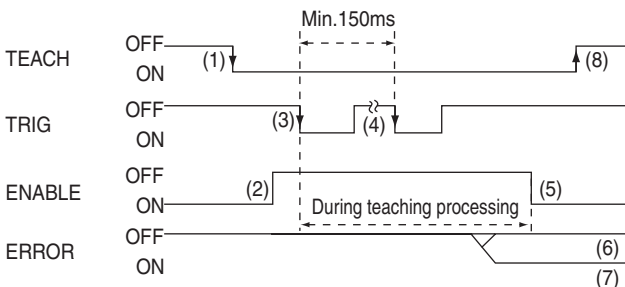

- (1) Turn the TEACH signal ON from the outside.
- (2) Confirm that the ENABLE signal has turned OFF.
- (3) Input the TRIG signal at the timing for measuring the workpiece to be taught.
- (4) Repeat the input in step (3) eight times. (Trigger inputs from the ninth time onwards are ignored.)
- (5) The ENABLE signal turns ON after teaching is completed. Check the state of the ERROR signal at this timing.
- (6) When teaching has been completed successfully, the ERROR signal stays OFF.
- (7) When teaching fails, the ERROR signal turns ON.
- (8) Turn the TEACH signal OFF and end teaching processing.
When teaching fails, the state before teaching was initiated is return to. Perform teaching again.
If the TEACH signal is turned OFF midway, teaching is disabled.

OMRON EUROPE B.V.

Wegalaan 67-69,
NL-2132 JD, Hoofddorp,
The Netherlands
Phone: +31 23 568 13 00
Fax: +31 23 568 13 88
www.eu.omron.com